

DKW 22-C KIT STANDARD INSTALLATION KIT

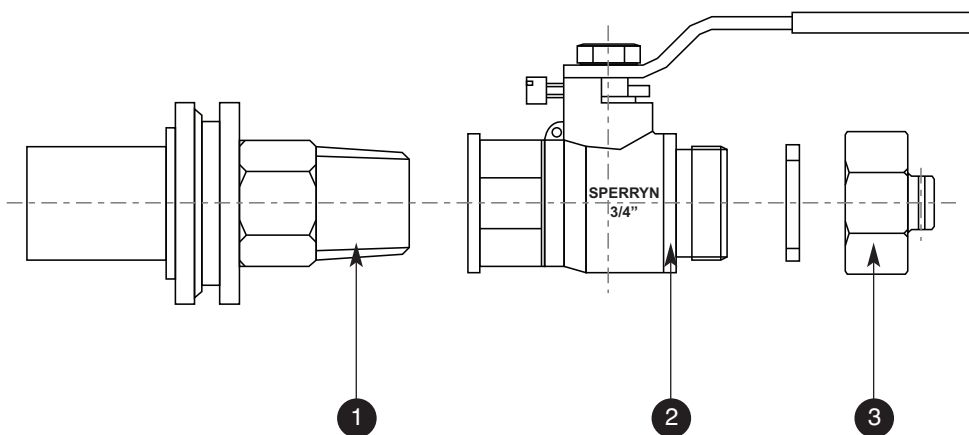

Item	Name	Description	Qty
1	AJ0012	METER FITTING WASK	1
2	F8325KS/K	3/4" BALL VALVE BS21 x BS746	1
3	5659KSW	SEALING CAP 3/4" + 3/4" RUBBER WASHER TO SUIT	1



DELTA ROAD
ST HELENS, WA9 2ED
TELEPHONE: +44 (0)1744 611 819

FAX: +44 (0)1744 26791
EMAIL: sperrynsales@cranebsu.com
www.sperryn.co.uk

Every effort has been made to ensure that the information contained in this publication is accurate at the time of publishing. Crane Ltd assumes no responsibility or liability for typographical errors or omissions or for any misinterpretation of the information within the publication and reserves the right to change without notice.

S_DKW22_0311
IOM_1241_V3