

DKW23 2ND STAGE METER KIT

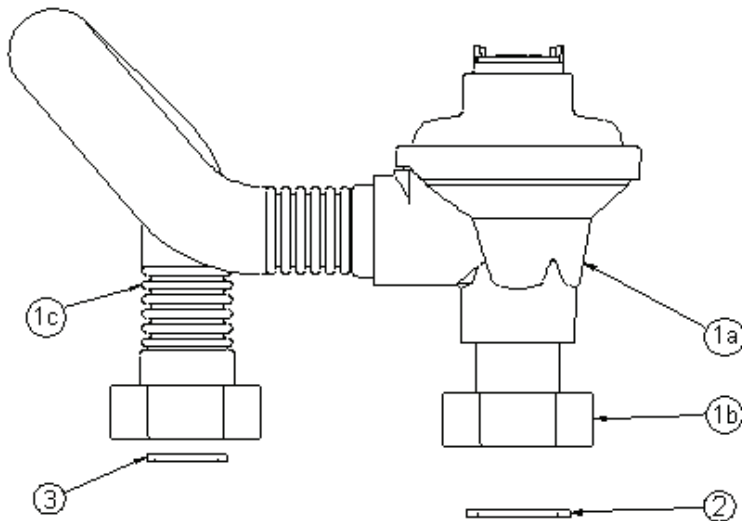

Item	Name	Description	Qty
1a	G940	¾" METER GOVERNOR	1
1b	X6533	CAP NUT	1
1c	4065KS/400	METER FLEX 400mm LONG	1
2	X4301	WASHER	2
3	X9267	¾" RUBBER WASHER	1

These gas installation kits have been pre assembled and tested during manufacture.
However, in accordance with Gas Regulations the final installation must be tested to applicable standards by a qualified person.

SPERRYN
GAS CONTROLS



DELTA ROAD
ST HELENS, WA9 2ED
TELEPHONE: +44 (0)1744 611 819

FAX: +44 (0)1744 26791
EMAIL: sperrysales@cranebsu.com
www.sperryn.co.uk

Every effort has been made to ensure that the information contained in this publication is accurate at the time of publishing. Crane Ltd assumes no responsibility or liability for typographical errors or omissions or for any misinterpretation of the information within the publication and reserves the right to change without notice.

S_DKW23_0511
IOM_1443_V5