

DKW 24

INSTALLATION KIT LIST

SSC3 1st Stage

DIAGRAM

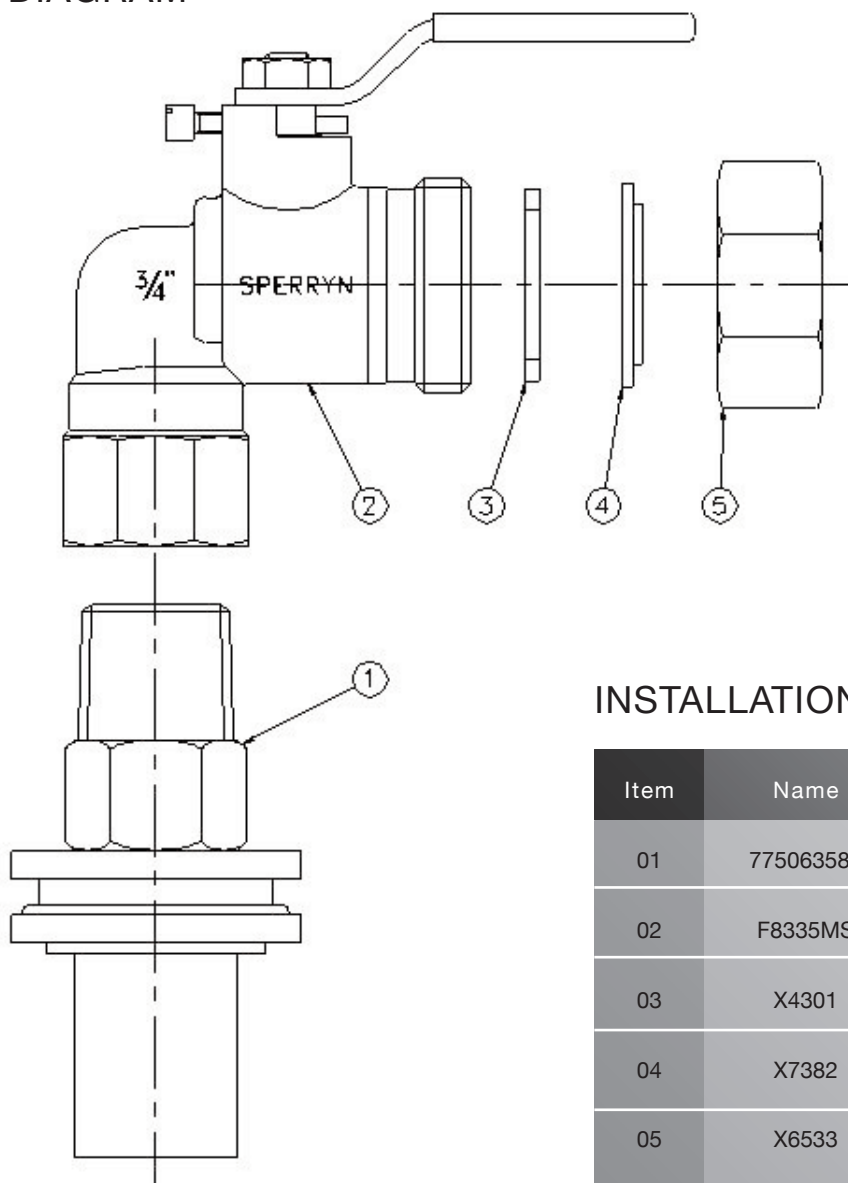

INSTALLATION KIT LIST

Item	Name	Description	Qty
01	775063583	Meter Fitting Drawlock	1
02	F8335MS	Angled Ball Valve 3/4" x 1"	1
03	X4301	Washer 1"	1
04	X7382	Blanking Cap 1"	1
05	X6533	Cap Nut 1"	1



DELTA ROAD,
ST HELENS, WA9 2ED
TELEPHONE: +44 (0)1744 611 811

FAX: +44 (0)1744 453675
EMAIL: sperrynsales@cranebsu.com
www.sperryn.co.uk

Every effort has been made to ensure that the information contained in this publication is accurate at the time of publishing. Crane Ltd assumes no responsibility or liability for typographical errors or omissions or for any misinterpretation of the information within the publication and reserves the right to change without notice.

S-DKW 24_07.10
IOM_1288